

BIDS AND AWARDS COMMITTEE FOR INFRASTRUCTURE PROJECTS (BAC-I)

BIDDING FOR THE CONSTRUCTION OF 9-STOREY RESIDENTIAL BUILDING IN FORT BONIFACIO, TAGUIG CITY

BID BULLETIN NO. 6

This Bid Bulletin clarifies queries received through email from prospective bidders and other matters pertaining to the above Project.

I. Queries/Questions by the Prospective Bidders

Queries/Questions	Clarifications
<p>Q1. Translation of documents</p> <p>Can Chinese documents with English translations be submitted without authentication if the deadline of submission will not be extended? Instead, the authenticated documents shall be presented during post-qualification.</p> <p>If in case time extension will not be accommodated, kindly allow the submission of Chinese documents with English translation only during the bid opening. The authenticated documents will be presented during post qualification.</p>	<p>No.</p> <p>In reference to Section 23.2 of the Revised IRR of RA9184, upon submission of bids, the eligibility requirements or statements, the bids, and all other documents to be submitted to the BAC must be in English. <u>If the eligibility requirements or statements, the bids, and all other documents submitted to the BAC are in foreign language other than English, it must be accompanied by a translation of the documents in English.</u> The documents shall be translated by the relevant foreign government agency, the foreign government agency authorized to translate documents, or a registered translator in the foreign bidder's country; and shall be authenticated by the appropriate Philippine foreign service establishment/post or the equivalent office having jurisdiction over the foreign bidder's affairs in the Philippines.</p>

	<p>However, for Contracting Parties to the Apostille Convention, the documents shall be authenticated through an apostille by the Competent Authority, as defined in Section 8.5.2 paragraph 4 of the 2016 revised IRR of RA No. 9184, except for countries identified by the DFA that will still require legalization (red ribbon) by the relevant Embassy or Consulate.</p> <p>Information about designated Competent Authorities may be found on the Apostille Section of the Hague Conference website under "Competent Authorities". Shown below is link to the list of Competent Authorities from Hague Conference website:</p> <p>www.hcch.net/en/instruments/conventions/authorities1/?cid=41</p>
<p>Q2. Request for extension On prospective bidders' requests for extension on the submission of bids to prepare the necessary eligibility, technical and financial requirements.</p>	<p>Please refer to the issued Bid Bulletin No. 5 regarding the Revised Timeline.</p>
<p>Q3. SLCC In line with the response on Bid Bulletin no. 3, Q3, stating that roof decks and basements are not qualified as a storey - could a completed 9-Storey building project but not the single largest contract of (1) JV partner and an SLCC of the lead JV partner for a completed 5-Storey (with roof decks and basements) building with a higher ABC than the project subject of bidding be considered?</p>	<p>No.</p> <p>The declared SLCC must be: a) similar to the contract to be bid; and b) equivalent to at least 50% of the ABC.</p> <p>In relation to item a, similar contract shall refer to the Construction of at least a 9-storey building.</p>
<p>Q4. Special PCAB License Whether or not, during the prequalification, the individual PCAB Licenses of potential partners to a JV, along with a Letter of Intent/Statement</p>	<p>Bidders intending to form a joint venture shall submit duly notarized statements from all the potential joint venture partners stating that they will enter into and abide by the provisions</p>

<p>for joint venture be submitted in lieu pending the release of the Special License by PCAB?</p>	<p>of the JV agreement in the instance that the bid is successful.</p> <p>Further, the Special PCAB license should be submitted upon award of the contract within ten (10) calendar days, together with other required documents, pursuant to Section 37.1 of RA9184 and its implementing rules and regulations.</p>
<p>Q5. Bidding Documents</p> <p>Will the BAC allow a sole entity that initially purchased the bidding documents to be a party to and submit a bid as part of a joint venture/consortium?</p>	<p>Yes.</p> <p>The GPPB provides in its Non-Policy Matter No. 062-2012, that:</p> <p><i>“(2) Can a supposed JV partner, taking into consideration the contents of a Letter of Intent (LOI) submitted by the other partner, use the Bidding Documents purchased by the latter and participate in the bidding?”</i></p> <p><i>RA 9184 and its IRR does not expressly provide that the purchase of Bidding Documents shall vest solely on a particular buyer or prospective bidder the right to participate in the bidding process using the very set of Bidding Documents purchased.</i></p> <p><i>Pursuant to Section 17.4 of the IRR, “[b]idders may be asked to pay for the Bidding Documents to recover the cost of its preparation and development. The BAC shall issue the Bidding Documents upon payment of the corresponding cost thereof to the collecting/disbursing officer of the procuring entity concerned.”</i></p> <p><i>A perusal of the cited provision shows that it does not in any way restrict the use or the transfer of the right or privilege arising from the purchase of the Bidding Documents. What is necessary, however, is that the Bidding Documents used by the bidder in submitting its bid has</i></p>

	<p><i>been paid for in case the procuring entity charges for its Bidding Documents.</i></p>
<p>Q6. CARI, ECC and Building Permits. Whether or not the CARI, ECC, and Building Permits are provided by Owner/BCDA.</p>	<p>No. The ABC is inclusive of all applicable taxes and fees i.e bonds, insurances, permitting, clearances, and among others. Thus, the winning bidder shall be responsible in securing all necessary permits and insurances.</p>
<p>Q7. Key Personnel 'Sanitary Engineer' is shown at Form for Annex "B" Statement of Availability of Key Personnel Page-41. However at ITB Bid Data Sheet Item 10.4 Page-19 List of Key Personnel, Sanitary Engineer is represented by Drainage Engineer.</p> <p>Please confirm that the Drainage Engineer and Sanitary Engineer is one person only.</p>	<p>Annex B - Statement of Availability of Key Personnel was amended. Please refer to Bid Bulletin no. 3: Section II. Other Amendments/ Modifications to the Bidding Documents, and its Annex A</p>
<p>Q8. Contract Documents At ITB Section III Bid Data Sheet it is indicated "Additional contract documents relevant to the Project that may be required by existing laws and/or the Procuring Entity, such as construction schedule and S-curve, manpower schedule, construction methods, equipment utilization schedule, construction safety and health program stamped "received" by the DOLE, and other acceptable tools of project scheduling."</p> <p>Please confirm that above-mentioned documents shall be part of Post-Qualification Documents or by further Procuring Entity's instruction through Bid Bulletin as implied by preposition 'may be'.</p>	<p>No. In reference to Section 21-Signing of the Contract of the Instructions to Bidders, the construction schedule and S-curve, manpower schedule, construction methods, equipment utilization schedule, construction safety and health program stamped "received" by the DOLE, and other acceptable tools of project scheduling shall be submitted within ten (10) calendar days upon receipt of the Notice of Award.</p> <p>For purposes of Post-Qualification, please refer to Section 20 of the Bid Data Sheet for the documents required to be submitted within five (5) calendar days from receipt of notice of post-qualification from the BAC.</p>

<p>Q9. Permits Please confirm if all statutory Permits are excluded in the scope of the Contractor and to be provided by Client / Navy.</p>	<p>Please refer to the answer in Q6.</p>
<p>Q10. Tapping of Power The tapping of Power will be along Lawton Ave and the application is under the Contractor. Water source is inside the Navy Camp and to be provided by the client. Please confirm.</p>	<p>The provision for both power and water is within the scope of works of the Contractor.</p>
<p>Q11. Please confirm if the reinforcing steel for splices added by the Contractor will be paid if the engineer approved and installed it to the project site.</p>	<p>No payment for additional quantities and items shall be made if such additional quantities and items were installed prior to securing of approval of the the Head of Procuring Entity (HoPE).</p>
<p>Q12. Sanitary / Plumbing In the Schedule of Equipment in Sheet no. P18-3 with 1 set of Booster pump (BP- T 1-2) 1-Stand by & 1 Duty which means there are two pumps in a set, But in the Drawing shown in Sheet no. P18-2 there were 4 units of Pumps. . (Refer to attached Photo)</p> 	<p>For this bidding, only 2 units of Transfer Pumps will be supplied & installed by the Contractor.</p>
<p>Q13. Preliminaries Whether or not construction of Barracks at project site is allowed.</p>	<p>Yes, subject to compliance with the requirements of the End User which shall be discussed during the project's kick-off meeting.</p>
<p>Q14. Preliminaries Please provide area (m2) requirements for the following temporary building: a. Canteen b. Workshop c. Warehouse d. Motorpool</p>	<p>There are no area requirements for the canteen, workshop, warehouse and motorpool. However, the Contractor shall submit, prior to the kick-off meeting, a site layout plan on its proposed temporary project site structures, facilities, and utilities. The submitted site layout plan must be approved by BCDA.</p>

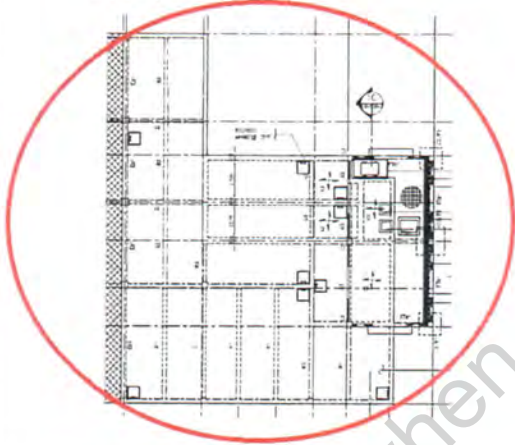
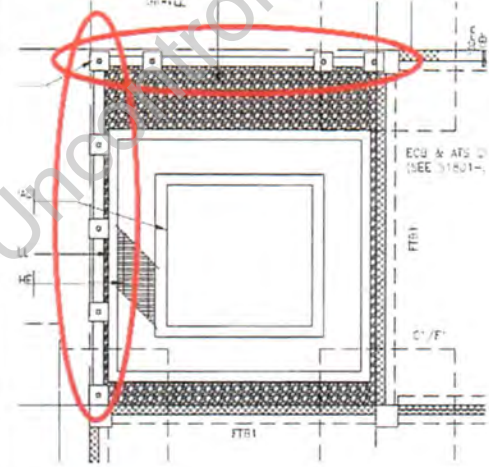
	<p>Please refer to the General Requirement Specifications Subsection 1.4.1. Office, Shops, Stores, and Workmen's Accomodation for Contractor under Section 1.4 Other Requirements.</p>
<p>Q15. Structural Works Building 18. Please provide slab tagging at the upper floor plan.</p> 	<p>Please refer to Sheet no. S18-2 for slab tagging (Bid Bulletin 5 Annex A)</p>
<p>Q16. Structural Works Building 18D2. Please provide details for the encircled item located at building 18D2.</p> 	<p>For the details, please refer to Sheet S18D2-4:Detail 2B.</p>
<p>Q17. Site Development Is there a testing requirement for riprap works? If yes, please specify.</p>	<p>There is no required test for the riprap works. Riprap is the ground cover of</p>

		the embankment, and the compaction shall be per Technical Specifications.
Q18. Mechanical Works	Please provide a schematic diagram for the Multi-split AC system.	<p>A multi-split AC system schematic diagram is not necessary since refrigerant piping layout is simpler for each FCU and is individually connected to the ACCU with its own individual pair of refrigerant pipings.</p> <p>VRF systems are more complex pipe routing with the use of splitters and having a single pair of RS and RL to be distributed to all the indoor units.</p>
Q19. Sewage Treatment Plant	Please specify the STP structure if above ground or underground.	<p>The STP is part of Contractor's scope of works and the Contractor shall hire a specialty STP technology provider based on the given Performance Specification. The final design of the STP, whether above ground or underground, should be subject to the approval of BCDA.</p> <p>For the performance specification of the STP, please refer to Section 02750 Sewage Treatment Plant Performance Specification of the Plumbing and Sanitary Technical Specifications.</p>
Q20. Plumbing Works	Please verify if the "Quadruplex Booster Pump & Sump Pump at Pump Room Building No. 18" as shown in the plans is included in the scope of works. This is also not included in the BOQ and Equipment schedule.	Please include only in the Scope of Works all equipment reflected in the Schedule of Equipment of sheet no. P18-3.
Q21. Electrical Works	Please confirm if there is only 1-Air Terminal Lightning Arrester per BOQ, while at plans there are 2 risers for the Lightning Protection System. Please provide the plan location of the Lightning Arrester at the Roof deck.	Yes. There is only 1-Air Terminal Lightning Arrester. Please refer to E10-10f.

<p>Q22. Architectural Toilet and Bath Accessories (American Standard) model codes in Technical Specifications is not available or obsolete (please see attached table)</p> <table border="1"> <tr> <td>1</td> <td>Toilet paper holder</td> <td>Architectural Spec</td> <td>2.3.1</td> </tr> <tr> <td>2</td> <td>Robe Hook</td> <td>Architectural Spec</td> <td>2.3.3</td> </tr> <tr> <td>3</td> <td>Towel Holder</td> <td>Architectural Spec</td> <td>2.3.4</td> </tr> <tr> <td>4</td> <td>Soap Dish</td> <td>Architectural Spec</td> <td>2.3.6</td> </tr> <tr> <td>5</td> <td>Shower Head</td> <td>Architectural Spec</td> <td>2.3.8</td> </tr> <tr> <td>6</td> <td>Angle valve body</td> <td>Architectural Spec</td> <td>2.3.9</td> </tr> <tr> <td>7</td> <td>Paper towel dispenser</td> <td>Architectural Spec</td> <td>2.3.10</td> </tr> </table>	1	Toilet paper holder	Architectural Spec	2.3.1	2	Robe Hook	Architectural Spec	2.3.3	3	Towel Holder	Architectural Spec	2.3.4	4	Soap Dish	Architectural Spec	2.3.6	5	Shower Head	Architectural Spec	2.3.8	6	Angle valve body	Architectural Spec	2.3.9	7	Paper towel dispenser	Architectural Spec	2.3.10	<p>BCDA is not requiring a specific brand name. Reference to brand name is not allowed in relation to Section 18 of the Revised IRR of RA9184.</p>
1	Toilet paper holder	Architectural Spec	2.3.1																										
2	Robe Hook	Architectural Spec	2.3.3																										
3	Towel Holder	Architectural Spec	2.3.4																										
4	Soap Dish	Architectural Spec	2.3.6																										
5	Shower Head	Architectural Spec	2.3.8																										
6	Angle valve body	Architectural Spec	2.3.9																										
7	Paper towel dispenser	Architectural Spec	2.3.10																										
<p>Q23. Fire Protection System Please verify which shall govern for the Sprinkler Heads, in plans the sprinkler specification is quick response while in BOQ is standard response.</p>	<p>The Sprinkler Heads should be 'quick response'. Please refer to Sheet FP10-2.</p>																												
<p>Q24. General Request for the list of BCDA Staff or Engineer to be deployed on the site.</p>	<p>The list of BCDA personnel or engineers to be deployed on-site shall be discussed during the project's kick-off meeting after the issuance of the</p>																												

	<p>Notice to Proceed to the winning bidder.</p>																																																																								
<p>Q25. General Request for information regarding the highlighted part of "GENERAL REQUIREMENTS" Part A "facilities for the engineer". (Please see attached file no.1)</p> <table border="1" data-bbox="284 683 896 1041"> <thead> <tr> <th>ITEM NO.</th> <th>DESCRIPTION</th> <th>UNIT</th> <th>QUANTITY</th> </tr> </thead> <tbody> <tr> <td colspan="4">PART A</td> </tr> <tr> <td colspan="4">A.1.1 FACILITIES FOR THE ENGINEER</td> </tr> <tr> <td>A.1.1 (1)</td> <td>Field Office for the Engineer - BCDA Staff</td> <td></td> <td></td> </tr> <tr> <td>A.1.1 (2)</td> <td>Field Office with Plans and Tools (Two (2) units @ 800sqm) outdoor use in Rural Areas. <i>Note: See Schedule A.</i></td> <td>sqm</td> <td>1600</td> </tr> <tr> <td>A.1.1 (3)</td> <td>Living Quarters for the Engineer (One (1) unit @ 100sqm) in Rural Areas. <i>Note: See Schedule A.</i></td> <td>sqm</td> <td>100</td> </tr> <tr> <td>A.1.1 (4)</td> <td>Provision of Furniture, Fixtures, Office Equipment and Appliances for the Field Office and Living Quarters. <i>(Schedule A)</i></td> <td>unit</td> <td>100</td> </tr> <tr> <td>A.1.1 (5)</td> <td>Provision of Office Supplies and Consumables. <i>(Schedule A)</i></td> <td>month</td> <td>24 (3)</td> </tr> <tr> <td colspan="4">A.1.2 Service Vehicles for the Engineer - BCDA Staff - Rental Basis</td> </tr> <tr> <td>A.1.2 (1)</td> <td>Provision of Two (2) units of New Service Vehicles. <i>(Schedule A)</i></td> <td>month</td> <td>24 (3)</td> </tr> <tr> <td>A.1.2 (2)</td> <td>Operation and Maintenance of Three (3) Service Vehicles.</td> <td>month</td> <td>24 (3)</td> </tr> <tr> <td colspan="4">A.1.3 Assistance to the Engineer - BCDA Staff</td> </tr> <tr> <td>A.1.3 (1)</td> <td>Provision of Survey Equipment and Survey Personnel. <i>Note: See Schedule E.1 and E.2</i></td> <td>month</td> <td>24 (3)</td> </tr> <tr> <td colspan="4">A.1.4 Progress Photographs</td> </tr> <tr> <td>A.1.4 (1)</td> <td>Progress Photographs. <i>Note: See Schedule A.</i></td> <td>month</td> <td>24 (3)</td> </tr> <tr> <td colspan="4">A.1.5 Communication Facilities for the Engineer - BCDA Staff</td> </tr> <tr> <td>A.1.5 (1)</td> <td>Provision of Radio Communication Equipment. <i>(Schedule A)</i></td> <td>unit</td> <td>100</td> </tr> <tr> <td colspan="4" style="text-align: center;">TOTAL COST - FACILITIES FOR THE ENGINEER</td> </tr> </tbody> </table>	ITEM NO.	DESCRIPTION	UNIT	QUANTITY	PART A				A.1.1 FACILITIES FOR THE ENGINEER				A.1.1 (1)	Field Office for the Engineer - BCDA Staff			A.1.1 (2)	Field Office with Plans and Tools (Two (2) units @ 800sqm) outdoor use in Rural Areas. <i>Note: See Schedule A.</i>	sqm	1600	A.1.1 (3)	Living Quarters for the Engineer (One (1) unit @ 100sqm) in Rural Areas. <i>Note: See Schedule A.</i>	sqm	100	A.1.1 (4)	Provision of Furniture, Fixtures, Office Equipment and Appliances for the Field Office and Living Quarters. <i>(Schedule A)</i>	unit	100	A.1.1 (5)	Provision of Office Supplies and Consumables. <i>(Schedule A)</i>	month	24 (3)	A.1.2 Service Vehicles for the Engineer - BCDA Staff - Rental Basis				A.1.2 (1)	Provision of Two (2) units of New Service Vehicles. <i>(Schedule A)</i>	month	24 (3)	A.1.2 (2)	Operation and Maintenance of Three (3) Service Vehicles.	month	24 (3)	A.1.3 Assistance to the Engineer - BCDA Staff				A.1.3 (1)	Provision of Survey Equipment and Survey Personnel. <i>Note: See Schedule E.1 and E.2</i>	month	24 (3)	A.1.4 Progress Photographs				A.1.4 (1)	Progress Photographs. <i>Note: See Schedule A.</i>	month	24 (3)	A.1.5 Communication Facilities for the Engineer - BCDA Staff				A.1.5 (1)	Provision of Radio Communication Equipment. <i>(Schedule A)</i>	unit	100	TOTAL COST - FACILITIES FOR THE ENGINEER				<p>Please refer to the Technical Specifications for General Requirements (Bid Bulletin 5 Annex B).</p>
ITEM NO.	DESCRIPTION	UNIT	QUANTITY																																																																						
PART A																																																																									
A.1.1 FACILITIES FOR THE ENGINEER																																																																									
A.1.1 (1)	Field Office for the Engineer - BCDA Staff																																																																								
A.1.1 (2)	Field Office with Plans and Tools (Two (2) units @ 800sqm) outdoor use in Rural Areas. <i>Note: See Schedule A.</i>	sqm	1600																																																																						
A.1.1 (3)	Living Quarters for the Engineer (One (1) unit @ 100sqm) in Rural Areas. <i>Note: See Schedule A.</i>	sqm	100																																																																						
A.1.1 (4)	Provision of Furniture, Fixtures, Office Equipment and Appliances for the Field Office and Living Quarters. <i>(Schedule A)</i>	unit	100																																																																						
A.1.1 (5)	Provision of Office Supplies and Consumables. <i>(Schedule A)</i>	month	24 (3)																																																																						
A.1.2 Service Vehicles for the Engineer - BCDA Staff - Rental Basis																																																																									
A.1.2 (1)	Provision of Two (2) units of New Service Vehicles. <i>(Schedule A)</i>	month	24 (3)																																																																						
A.1.2 (2)	Operation and Maintenance of Three (3) Service Vehicles.	month	24 (3)																																																																						
A.1.3 Assistance to the Engineer - BCDA Staff																																																																									
A.1.3 (1)	Provision of Survey Equipment and Survey Personnel. <i>Note: See Schedule E.1 and E.2</i>	month	24 (3)																																																																						
A.1.4 Progress Photographs																																																																									
A.1.4 (1)	Progress Photographs. <i>Note: See Schedule A.</i>	month	24 (3)																																																																						
A.1.5 Communication Facilities for the Engineer - BCDA Staff																																																																									
A.1.5 (1)	Provision of Radio Communication Equipment. <i>(Schedule A)</i>	unit	100																																																																						
TOTAL COST - FACILITIES FOR THE ENGINEER																																																																									
<p>Q26. Bill of Quantities The below Schedules are shown at BOQ to be included at FACILITIES FOR THE ENGINEER. However, there are no details. Please provide descriptions/ definitions/ drawings of the following Schedules:</p> <ol style="list-style-type: none"> Schedule A.1 Schedule A.2 Schedule B Schedule C Schedule D Schedule E.1 Schedule E.2 Schedule F 	<p>Please refer to the Technical Specifications for the General Requirements (Bid Bulletin 5 Annex B).</p>																																																																								
<p>Q27. Electrical Per Plan, the Capacity Load of 2PP1.1N Typical to 2PP9.90N is 150AT/125AF but as per BOQ the Capacity Load is 125AT/150AF. What Ampere Trip will be used?</p>	<p>Per BOQ, the correct rating is 150 AT/250 AF. Please refer to (D) Electrical Works-Building, BOQ, Power System, pay Item 1102 (2) 10.13.</p>																																																																								

All provisions and statements in the bidding documents inconsistent with this Bid Bulletin are either modified or rendered ineffective, as the case may be.

Issued on 16 September 2022.

BIDS AND AWARDS COMMITTEE FOR INFRASTRUCTURE (BAC-I)

ATTY. GISELA Z. KALALO
Chairperson

Uncontrolled when printed or emailed

LINKS FOR THE ANNEXES:

Annex A - 19-040_S18-2 UPPER FLOOR FRAMING PLAN slab tagging

<https://drive.google.com/file/d/1NQnX6SXI9wVWYyQcu3S7iyNZrC37Og9Z/>

Annex B - Technical Specifications for the General Requirements

https://drive.google.com/file/d/1er4-VUk0HKGLaiv7PqaDAd_yCRM_MBLs/

Uncontrolled when printed or emailed